

Discovery

Optical Smoke Detector



Product overview

Product	Optical Smoke Detector
Part No.	58000-600
Digital Communication	Discovery (XP95 and CoreProtocol® compatible)

Compliance



Product information

The Discovery Optical Smoke Detector works on the light scatter principle and is ideal for applications where slow burning or smouldering fires are likely.

- Responds well to slow burning, smouldering fires
- Well suited for accommodation decks, passages and escape routes
- Unaffected by wind or atmospheric pressure
- Rejection of transient signals
- Remote test feature
- Five EN54 approved response modes

Note: For system compatibility and feature support of this device, please refer to your chosen panel manufacturer.

Technical data

All data is supplied subject to change without notice. Specifications are typical at 24V, 25°C and 50% RH unless otherwise stated.

Detection principle	Photo-electric detection of light scattered in a forward direction by smoke particles						
Chamber configuration	Horizontal optical bench housing an infrared emitter and sensor arranged radially to detect forward scattered light						
Sensor	Silicon PIN photo-diode						
Emitter	GaAlAs infra-red light emitting diode						
Sampling frequency	Once per second						
Supply Wiring	Two wire supply, polarity insensitive						
Terminal functions	<table border="0"> <tr> <td>L1 & L2</td> <td>Supply in & out connections</td> </tr> <tr> <td>+R</td> <td>Remote indicator positive connection (internal 2.2 kΩ resistance to positive)</td> </tr> <tr> <td>-R</td> <td>Remote indicator negative connection (internal 2.2 kΩ resistance to negative)</td> </tr> </table>	L1 & L2	Supply in & out connections	+R	Remote indicator positive connection (internal 2.2 kΩ resistance to positive)	-R	Remote indicator negative connection (internal 2.2 kΩ resistance to negative)
L1 & L2	Supply in & out connections						
+R	Remote indicator positive connection (internal 2.2 kΩ resistance to positive)						
-R	Remote indicator negative connection (internal 2.2 kΩ resistance to negative)						
Digital communication	Discovery, (XP95 and CoreProtocol compatible)						
Modulation voltage	5–9 V peak to peak						
Operating voltage	17 V - 28 V dc						
Quiescent current	300 μA						
Power-up surge current	1 mA						
Maximum power-up time	10 seconds						
Alarm indicator	Two clear 360° viewable light emitting diode (LED) illuminating red in alarm. Optional remote LED						
Alarm current, LED illuminated	3.5 mA						
Remote output characteristics	Connects to positive line through 4.5 kΩ (5 mA maximum)						
Clean-air analogue value	23 +4/-0						
Alarm level analogue value	55						
Operating temperature	-40°C to +70°C						
Storage temperature	-40°C to +80°C						
Humidity	0% to 95% RH (no condensation or icing)						
Vibration, impact and shock	EN54 - 7						
Standards and approvals	EN 54-7, CPR, LPCB, VdS, BOSEC, SBSC, FG, CCMG, Kazaksthan						
Dimensions	100 mm diameter x 42 mm height (50 mm height with XPERT 7 base)						
Weight	105 g (160 g with XPERT 7 mounting base)						
Materials	<table border="0"> <tr> <td>Housing</td> <td>White flame-retardant polycarbonate</td> </tr> <tr> <td>Terminals</td> <td>Nickel plated stainless steel</td> </tr> </table>	Housing	White flame-retardant polycarbonate	Terminals	Nickel plated stainless steel		
Housing	White flame-retardant polycarbonate						
Terminals	Nickel plated stainless steel						

All information in this document is given in good faith but Apollo Fire Detectors Ltd cannot be held responsible for any omissions or errors. The company reserves the right to change the specifications of products at any time and without prior notice.

36 Brookside Road, Havant | Tel: +44 (0)23 9249 2412 | Email: sales@apollo-fire.com
 Hampshire, PO9 1JR, UK. | Fax: +44 (0)23 9249 2754 | Web: www.apollo-fire.co.uk



A Halma company

© Apollo Fire Detectors Ltd 2021



Operation

The Discovery Optical Smoke Detector has a white moulded polycarbonate case with wind-resistant smoke inlets. The indicator LEDs are colourless when the detector is in quiescent state and red in alarm. Within the case is a printed circuit board which on one side has the light proof labyrinth chamber with integral gauze surrounding the optical measuring system and on the other the address capture, signal processing and communications electronics.

An infrared light emitting diode within its collimator is arranged at an obtuse angle to the photo-diode. The photo-diode has an integral daylight blocking filter.

The IR LED emits a burst of collimated light every second. In clear air the photo-diode receives no light directly from the IR LED because of the angular arrangement and the chamber baffles. When smoke enters the chamber it scatters light from the emitter IR LED onto the photo-diode in an amount related to the smoke characteristics and density. The photo-diode signal is processed to provide an analogue value for transmission when the detector is interrogated.

Discovery Optical Smoke Detector schematic diagram

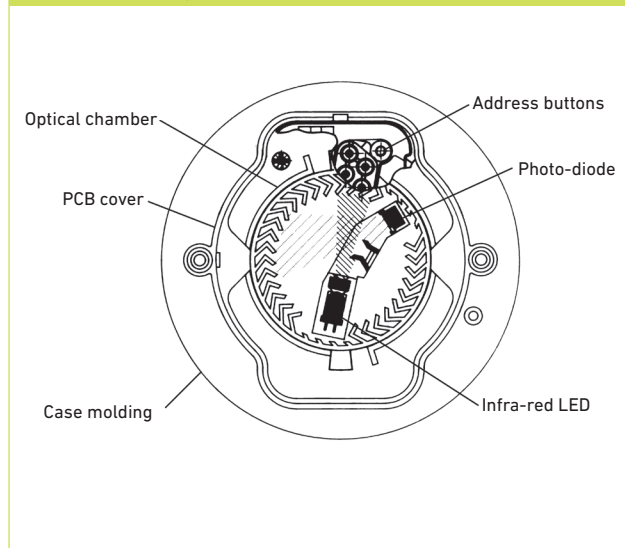

Electrical description

The Discovery Optical Smoke Detector is designed to be connected to a two wire loop circuit carrying both data and a 17 V to 28 V dc supply. The detector is connected to the incoming and outgoing supply via terminals L1 and L2 in the mounting base. A remote LED indicator requiring not more than 4 mA at 5 V may be connected between the +R and -R terminals. An earth connection terminal is also provided. The detector is calibrated to give an analogue value of 23 \pm 4/-0 counts in clean air. This value increases with smoke density. A count of 55 corresponds to the alarm level analogue value.

Features

Response modes

Discovery Optical Smoke Detectors can be operated in any one of five EN54 approved response modes, which can be selected through the fire control panel. Each mode corresponds to a unique response behaviour, which is related to sensitivity to fire. Mode 1 gives a higher sensitivity to fire than Mode 5.

Discovery Optical Smoke Detector Response Times

Mode	Alarm threshold (%/m)	dB/m	Minimum time to alarm (Seconds)
1	1.4	0.08	5
2	1.4	0.08	30
3	2.1	0.12	5
4	2.1	0.12	30
5	2.4	0.14	5

Flashing LEDs

Discovery Optical Smoke Detectors have two integral LED indicators, which can be illuminated at any time by the fire control panel to indicate detectors in alarm. A flashing LED mode can also be programmed to activate each time a detector is polled.

Remote test feature

The remote test feature is enabled from the fire control panel. On receipt of the command signal from the fire control panel, the detector is forced electrically into alarm. An analogue value of 85 is returned to the fire control panel to indicate that the detector is working correctly.

Rejection of transient signals

Discovery detectors are designed to give low sensitivity to very rapid changes in the sensor output, since these are unlikely to be caused by real fire conditions, resulting in fewer false alarms.

Drift compensation

Discovery Optical Smoke Detectors include compensation for signal drift to compensate for changes in the sensor output caused, for example by dust in the chamber, and will therefore hold the sensitivity at a constant level even with severe chamber contamination. This increased stability is achieved without significantly affecting the detectors sensitivity to fire whilst still meeting the requirements of the EN54 standard.

EMC Directive 2014/30/EU

The Discovery Optical Smoke Detector complies with the essential requirements of the EMC Directive 2014/30/EU, provided that it is used as described in this data sheet.

A copy of the Declaration of Conformity is available from the Apollo website: www.apollo-fire.co.uk.

Construction Products Regulation 305/2011/EU

The Discovery Optical Smoke Detector complies with the essential requirements of the Construction Products Regulation 305/2011/EU.

A copy of the Declaration of Performance is available from the Apollo website: www.apollo-fire.co.uk

Discovery Optical Smoke Detector dimensions

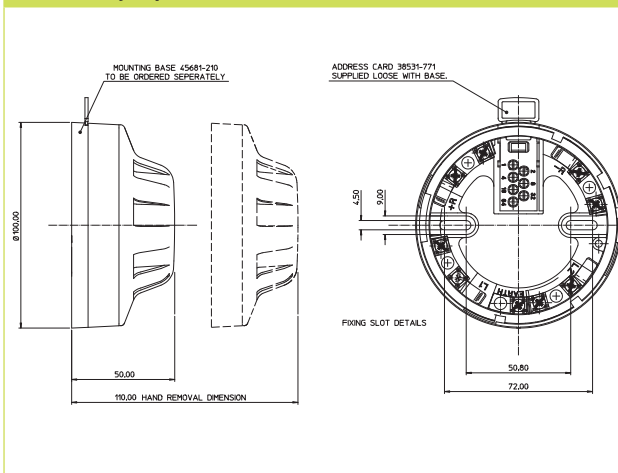

Response characteristics of Discovery Optical Smoke Detectors

Type of fire	Response
Overheating/thermal combustion	Very Good
Smouldering/glowing combustion	Moderate/Good
Flaming combustion	Good
Flaming with high heat output	Good
Flaming - clean burning	Poor