

Category W Loop Powered VADs



Product overview

Product Type	Visual Alarm Device
Part No.	55000-741 (W-2.4-6, red body) 55000-744 (W-2.4-6, white body)
Digital Communication Protocol	XP95®, Discovery® and CoreProtocol® compatible

Product information

The addressable Loop Powered Visual Alarm Devices (VADs) have been developed as primary or supplementary alarm devices. VADs may be used in situations where there is a risk that sounders will not be heard. This occurs, for example, where there is high background noise such as in a workshop or in a machine room.

It might also be required where deaf or hearing impaired persons may be present.

- Uses high intensity LED
- EN 54-23 Compliant Category W VAD
- Coverage W-2.4-6
- Flash rate 0.5Hz
- Fault signal if LED check failed
- Locking mechanism (grub screw)
- Wide angle of visibility
- Synchronised flash rates with the Apollo Protocol

Technical data

Coverage class	W-2.4-6
Flash colour	White
Flash rate	0.5 Hz
Supply voltage (Vmin-Vmax)	17-28 V DC (polarity sensitive)
Digital communication protocol	XP95, Discovery and CoreProtocol compatible
Quiescent	280 µA
Power-up surge current	1.5 mA
Alarm current (LED on)	16 mA
Operating temperature*	-10°C to +55°C
Humidity (no condensation or icing)	0% to 95% RH
Vibration, impact and shock	EN 54-23
IP Rating (Tested and approved by TRaC Global Limited testing laboratory)	IP54 (when used with Part No. 45681-210, Part No. 45681-284 or Part No. SA5000-200 Mounting Base) IP55 (when using the Deck-head Mounting Box Part No. 45681-217)
Standards and approvals	EN 54-23, CPR, LPCB and VdS
Dimensions	100 mm diameter x 48 mm height (56 mm height with XPERT 7 Mounting Base) see Figure 2
Weight	105g

* Tested by Apollo Fire Detectors Limited to -40°C to +70°C

Application

The Loop Powered Addressable Visual Alarm Device is a local-area VAD designed for indoor use.

The VAD can be connected to systems with XP95, Discovery or Soteria® devices on the loop.

The Loop Powered VAD can be fitted to any XPERT 7 or XPERT 8 Mounting Base.

The base must be positioned on the wall, with the XPERT card pointing downwards for correct orientation and coverage.

When fitted to an Ancillary Base Sounder (Part No. 45681-276), the sounder activation will be controlled by the VAD.

When fitted to an Integrated Base Sounder the devices can be controlled separately via their individual address.

Figure 1 shows the coverage volume for the wall category VAD with an example calculation.

Electrical Considerations

The VAD is loop powered and requires no external power supply. It operates at 17-28 V dc.

Category W Loop Powered VADs

Figure 1 Category W Loop Powered VAD with XPERT 7 Mounting Base coverage area and mounting instructions

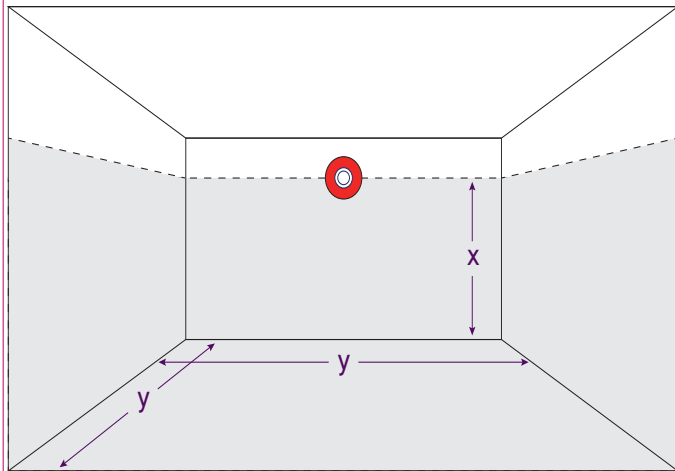

X - The maximum height of the device on the wall in metres with a maximum value of 2.4 m.

Y - The width in metres of the square volume covered when the device is mounted to the wall at required height.

Part No. 55000-741 and 55000-744 (W-2..4-6) - coverage cuboid volume of 2.4 m x 6 m x 6 m = 86.4 m³.

Table 1 Digital communications protocol compatibility

Protocol	Device behaviour
XP95/Discovery†	XP95
CoreProtocol†	XP95

† Fire control panel dependant

Loop Loading

Up to 12 VADs may be fitted between standard XP95 isolators (Part No. 55000-700/710/720) or isolating mounting bases (Part No. 45681-284, which replaced Part No. 45681-321). The maximum number of devices is dependent on the devices individual coverage class.

In order to determine the exact number in a loop please use the 'Loop Calculator' available as a free download on the Apollo website: www.apollo-fire.co.uk

Addressing

The Loop Powered VAD must be assigned an address by coding the XPERT card.

Mechanical Construction

The case of the VAD is made of white or red self extinguishing polycarbonate with stainless steel contacts.

EMC Directive 2014/30/EU

The VAD complies with the essential requirements of the EMC Directive 2014/30/EU, provided that it is used as described in this datasheet.

A copy of the Declaration of Conformity is available from the Apollo website: www.apollo-fire.co.uk

Conformity of the VAD with the EMC Directive, does not confer compliance with the directive on any apparatus or systems connected to it.

Construction Products Regulation 305/2011/EU

The VAD complies with the essential requirements of the Construction Products Regulation 305/2011/EU.

A copy of the Declaration of Performance is available from the Apollo website: www.apollo-fire.co.uk

Figure 2 Category W Loop Powered VAD (W-2.4-6) with XPERT 7 Mounting Base dimensional drawing

